

Svuotamento bins e casse / Bin and crate emptying



Immergitore di bins a ciclo continuo Water Bin Submerger

Adatto all'immersione in acqua di frutta delicata, mediante una pinza pneumatica che esegue il decatastamento e l'immersione dei bins pieni e l'accatastamento di quelli vuoti.

Dotato di un dispositivo autoregolante per bins di diverse altezze; le velocità sono regolabili tramite inverter.

Disponibile anche nella versione con vasche laterali e pinza rotante per lo svuotamento dei prodotti che non galleggiano.



Water bin continuous submerger

It is suitable for submerging delicate fruit into water tank by means of a pneumatic clamp carrying out destacking and submerging of full bins and stacking of empties.

It is provided with an autoregulating base and electronic speed variation.

Also available with side tanks and with rotary clamp suitable for not floating products.



LAYOUT

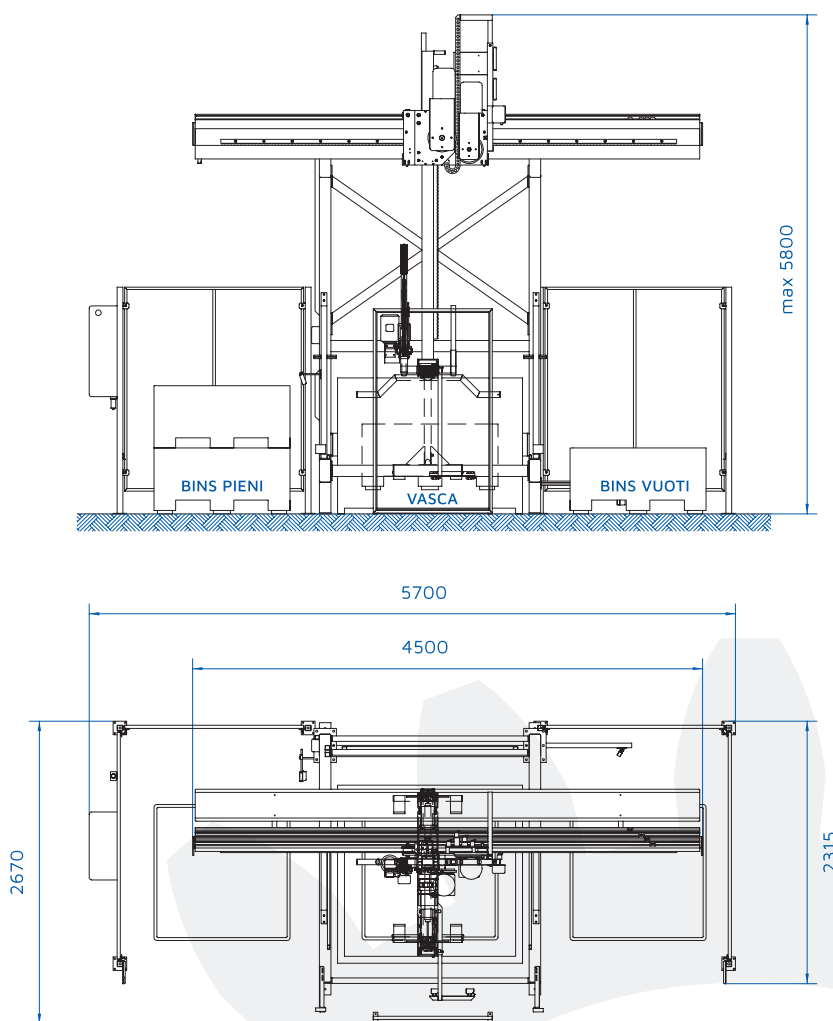

DATI TECNICI
TECHNICAL DATA

PRODUZIONE ORARIA
HOURLY PRODUCTION

max **25** bins

POTENZA ELETTRICA INSTALLATA
INSTALLED ELECTRICAL POWER

kW **1,1**

DIMENSIONI BINS (mm)
BIN DIMENSIONS (mm)

W **800 ÷ 1220** / L **1100 ÷ 1200** / H **540 ÷ 780**

PRODOTTO DI LAVORAZIONE
PRODUCTS PROCESSED



Mele
Apples



Ciliegie
Cherries



Melanzane
Eggplant



Pere Abate
Abate Pears



Pere Williams
Williams Pears