

Svuotamento bins e casse / *Bin and crate emptying*

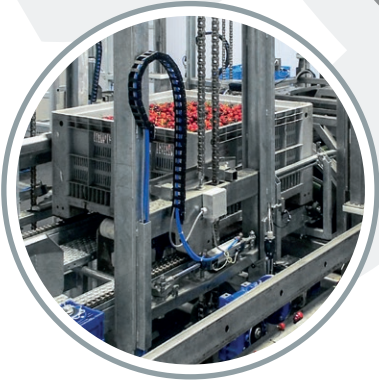

PARTICOLARI
DETAILS



Sistema di immersione bins

Insieme di macchinari pensato per le esigenze delle grandi produzioni, che permette di gestire in maniera automatica l'intero ciclo di immersione dei bins in acqua: trasporto, decatastamento, immersione, prelievamento, accatastamento e trasporto in uscita.

Tramite un pratico touch screen sarà possibile accedere a tutte le regolazioni necessarie ad ottimizzare questo sistema con il tipo di lavorazione desiderato.



Box emptying system

This equipment is designed for the needs of large production volumes. This system facilitates the management of the entire cycle of bins water immersion: transport, unstacking, damping, collecting, stacking and dispensing.

The equipment is operated via a convenient touch screen which can be also used to optimize specific processing parameters.



LAYOUT

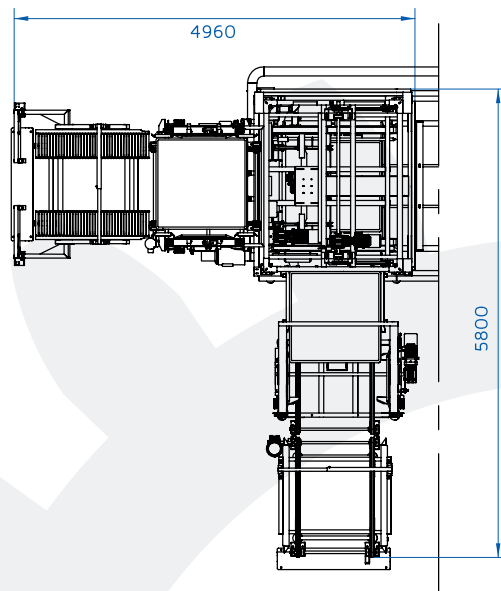
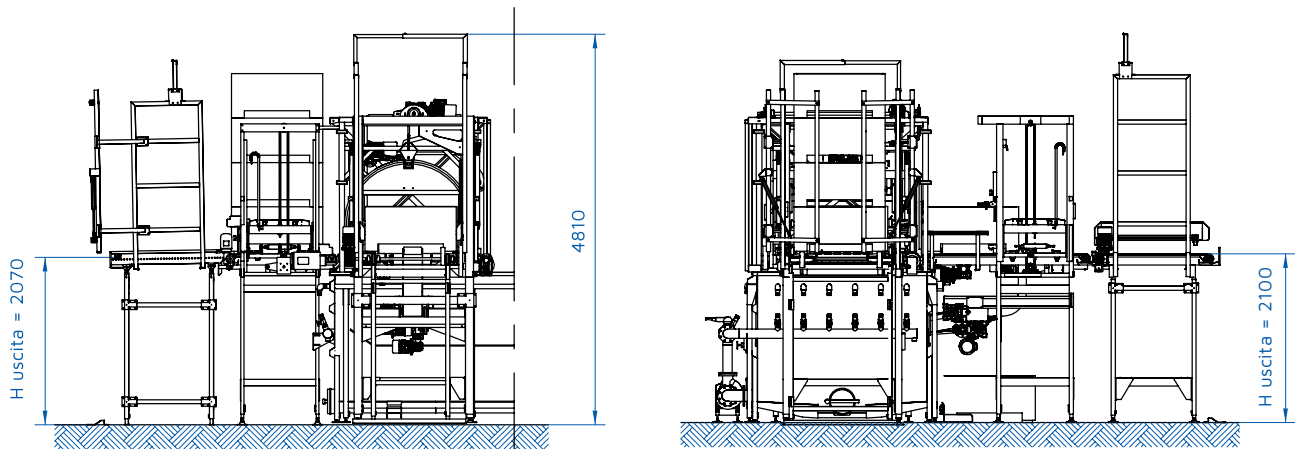

DATI TECNICI
TECHNICAL DATA

POTENZA ELETTRICA INSTALLATA
INSTALLED ELECTRICAL POWER

kw 7

DIMENS. BINS / BIN DIMENSIONS (mm)

W 1100÷1220 - L 1000÷1200
H 540÷800

PRODUZIONE ORARIA
HOURLY PRODUCTION

max 80 bins

CONSUMO ARIA
AIR CONSUMPTION

40 NI/min

PRODOTTO DI LAVORAZIONE
PRODUCTS PROCESSED



Ciliegie
Cherries



Mele
Apples



Sede Centrale:

ICOEL S.r.l. - FONDI (LT) 04022 - Via della Torre, 83 - Tel. +39 0771 511416 / 511929
Fax +39 0771 511417 - info@icoel.com

Ufficio Commerciale:

CESENA (FC) 47522 - Via Lelio Basso, 160 - Tel. +39 0547 404989